



# Mk 3

## HEAVY DUTY ROADHEADER



*Mk 3 on 1 in 4 incline test ramp*

<b>Mk 3 OUTLINE DATA</b>	<b>TYPICAL SPECIFICATION</b>
<b>Machine Weight (Base Machine)</b>	<b>85 tonnes</b>
<b>Total Power (Standard Machine)</b>	<b>From 284 kW</b>
<b>Power on Cutting Boom (Standard Machine)</b>	<b>From 147 kW</b>
<b>Hydraulic System Working Pressure</b>	<b>140 bar</b>
<b>Tracking Speeds – Sumping/Flitting</b>	<b>0.03/0.09 m/sec</b>
<b>Ground Pressure</b>	<b>1.4 kg/cm<sup>2</sup></b>

The Mk 3 roadheader is designed to give greater strength and power to the well proven cutting boom principle.

A powerful boom assembly with high arcing and lifting forces enables the machine to cut harder stratas in roadways up to 6000 mm high.

The excavated material is loaded by twin gathering arms or starwheels onto a centrally mounted twin strand scraper conveyor powered by an electric motor. The gathering apron has the facility to be sumped forward 400 mm to improve gathering on down gradients.



**YOUR PARTNER  
FOR ALL ROUND QUALITY AND RELIABILITY**



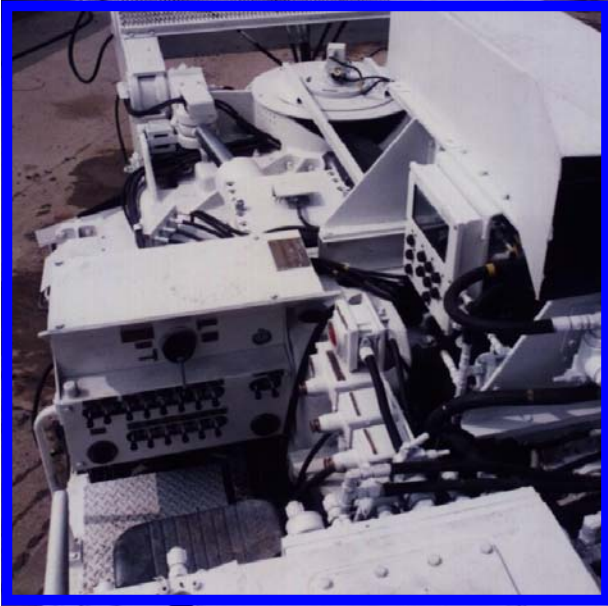

**Mk 3 drivers control panel**



**OPTIONS include:**

- **Raised Pressure Water Systems** – improved dust suppression, reduced risk of incendive sparking, increased cutter tool life.
- **Operators Canopy** – custom designed to suit individual application requirements.
- **Gas Detection System**
- **Diagnostic Control System** – monitors state of selected electrical and water functions.
- **Coanda Air Curtain** – retains dust forward of the operators position for extraction by mine ventilation system

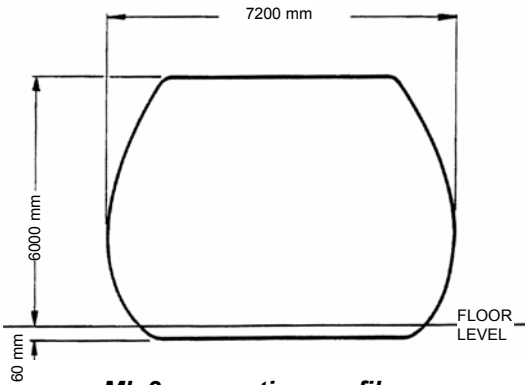

**Mk 3 excavation profile**

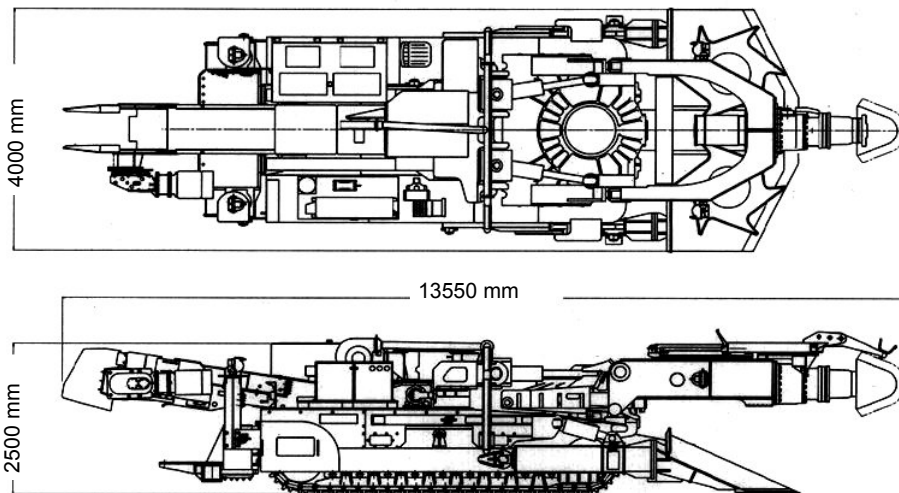

Document Issue 1 Revision 2 05/08/03

**PLEASE NOTE – Data is intended as a guide only as machines may vary according to specification requirements.**



**DOSCO OVERSEAS ENGINEERING LTD**  
 Ollerton Road, Tuxford, Newark Nottinghamshire, NG22 0PQ England  
 Telephone: + 44 (0) 1777 870621 Facsimile: + 44 (0) 1777 871580  
 E-mail: info@dosco.co.uk Website: www.dosco.co.uk



A member of the Amco Corporation Plc group of companies.